

THIS DRAWING IS UNPUBLISHED. RELEASED FOR PUBLICATION  
 © COPYRIGHT - By - ALL RIGHTS RESERVED.

LOC	DIST	REVISIONS					
GP	00	P	LTR	DESCRIPTION	DATE	DWN	APVD
		P		REVISED PER ECO-11-004835	11MAR11	RK	HMR

STRAIN RELIEF STAPLE (1 SUPPLIED)  
 MATERIAL: STEEL  
 FINISH: BRIGHT TIN OVER NICKEL

CABLE SUPPLIED BY CUSTOMER  
 SEE TABLE FOR DIAMETER

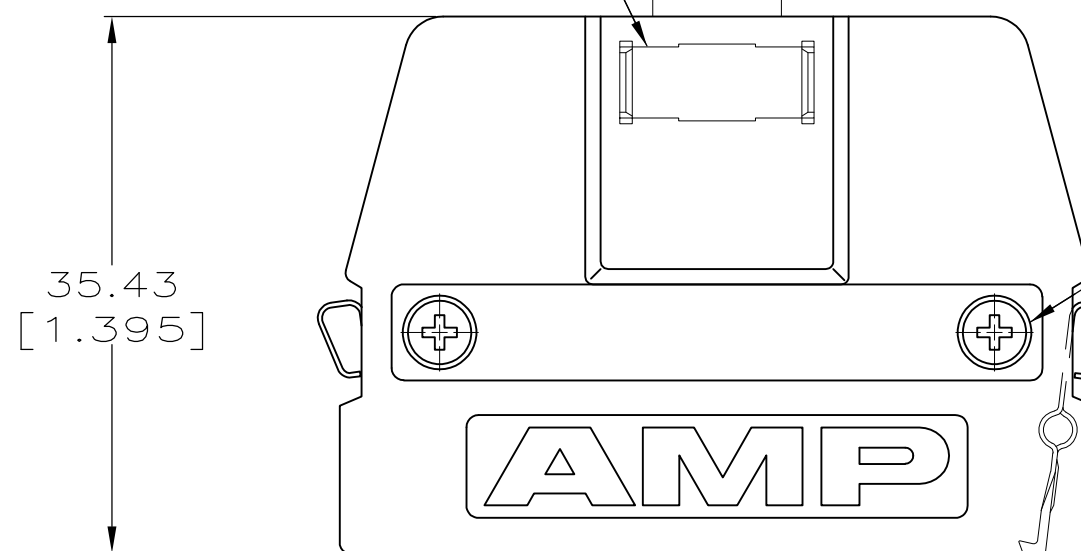

MACHINE SCREW (2 SUPPLIED)  
 #2-56 UNC X 6.35 [.250]

SPRING LATCH (2 SUPPLIED)  
 MATERIAL: STAINLESS STEEL

CONNECTOR (MUST BE PURCHASED SEPARATELY)

UPPER BACKSHELL (1 SUPPLIED)  
 MATERIAL: ZINC  
 FINISH: NICKEL OVER COPPER

12.19 [.480]

10.16 [.400]

LOWER BACKSHELL (1 SUPPLIED)  
 MATERIAL: ZINC  
 FINISH: NICKEL OVER COPPER

**COPYRIGHT 2005  
 TE CONNECTIVITY CORP  
 ALL RIGHTS RESERVED**

2	5749193-2
1	5749193-1
CABLE DIA	PART NUMBER

- 1 9.02[.355] MAX CABLE DIAMETER.
- 2 10.16[.400] MAX CABLE DIAMETER.
- 3. PARTS PACKAGED AS A UNIT KIT.

THIS DRAWING IS A CONTROLLED DOCUMENT.		DWN G.PETERS 25AUG05	<b>STE</b> TE Connectivity		
DIMENSIONS: INCHES		CHK S.SHUEY 25AUG05			
TOLERANCES UNLESS OTHERWISE SPECIFIED:		APVD M.WALMSLEY 25AUG05	NAME		
0 PLC ± -		PRODUCT SPEC	KIT, UNASSEMBLED, 50 POSITION, STRAIGHT EXIT, UNKEYED, AMPLIMITE .050 Seies		
1 PLC ± -		APPLICATION SPEC	SIZE	CAGE CODE	DRAWING NO
2 PLC ± -		WEIGHT	A3	00779	C-5749193
3 PLC ± 0.38[.015]		CUSTOMER DRAWING	SCALE	SHEET	REV
4 PLC ± -			1:1	1 OF 1	P
ANGLES ± -					
FINISH					
MATERIAL					